

Changer

Assembly Instructions

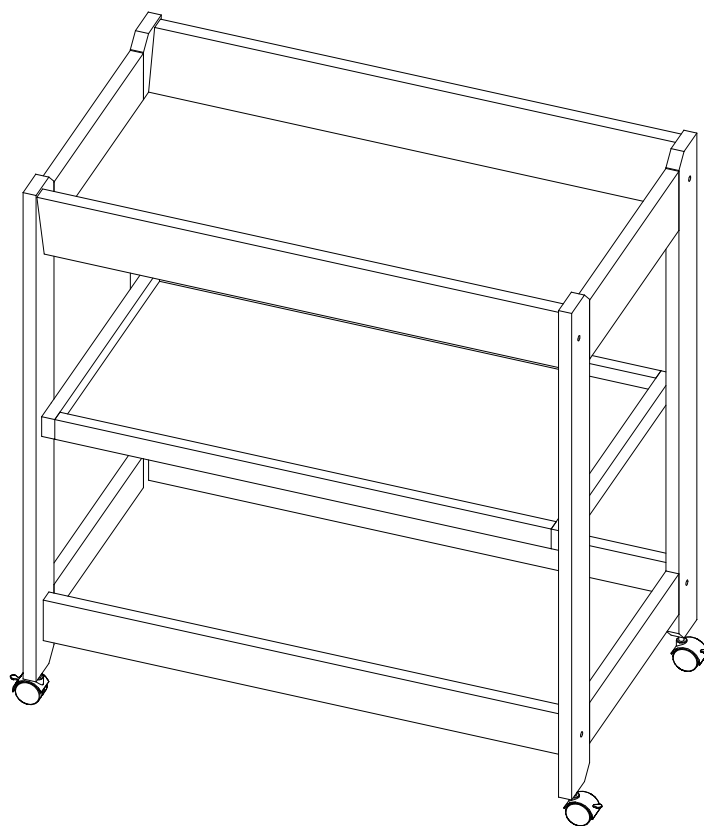

**IMPORTANT:THE ASSEMBLY OF THIS PRODUCT
MAY REQUIRE TWO PEOPLE**

本製品の組み立ては2人で行ってください。

**IMPORTANT:
PLEASE READ THE INSTRUCTIONS CAREFULLY AND KEEP FOR FUTURE REFERENCE**

本製品の組立を開始する前に必ずこの取扱書をお読みください。
お読みになったら大切に保管してください。

Read all instructions BEFORE assembly and USE of the product. KEEP INSTRUCTIONS FOR FUTURE USE.

IMPORTANT, RETAIN FOR FUTURE REFERENCE

PLEASE READ CAREFULLY

Boori Australia Pty Ltd
 18-20 Charles Street
 St. Marys Sydney NSW
 2760 Australia
 Ph: 61 2 9833 3769
 Fax: 61 2 9673 4240



Boori (UK) Ltd
 Unit 1, Transigo
 Gables Way
 Thatcham
 RG19 4ZA
 Ph: (44) 016 3529 5670
 Fax: (44) 016 3587 7552

Boori USA LLC
 20 Chapin Road, Suite 1001
 Po Box 406
 Pine Brook, NJ 07058
 Ph: +1 973 577 6933
 Fax: +1 973 577 6934

ブーリジャパン(株)
 〒141-0031
 東京都品川区西五反田7-22-17
 TOCビル5F
 Tel: 03-6420-0024
 Fax: 03-6420-0025
 E-mail: info@boori.co.jp

Instructions for Changer

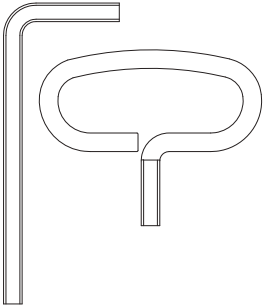
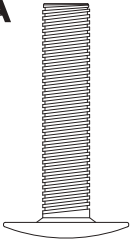
Hardware and Parts List

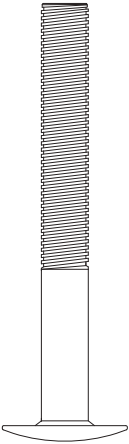
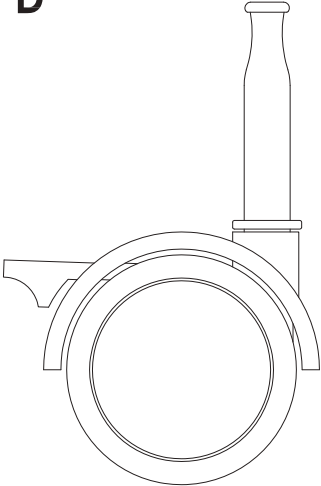
2 Allen Keys	4 x 28mm Connecting bolts	16 x Wooden dowels	8 x 54mm Connecting bolts	4 x Castors
	<p>A</p>  <p>Actual size</p>	<p>B</p> 	<p>C</p>  <p>Actual size</p>	<p>D</p> 

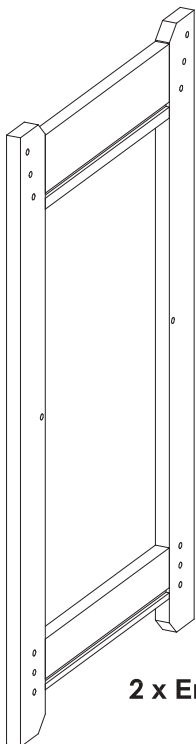

2 x End Panels

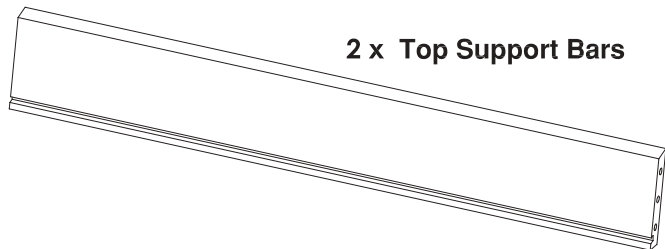

2 x Top Support Bars

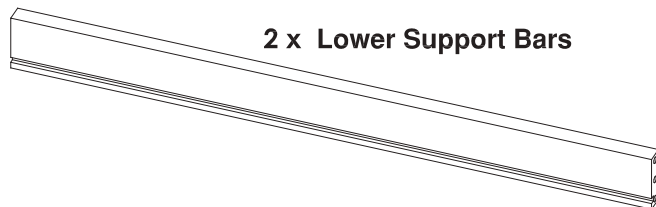

2 x Lower Support Bars

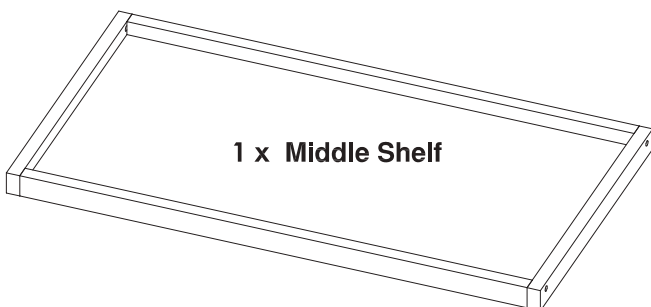

1 x Middle Shelf

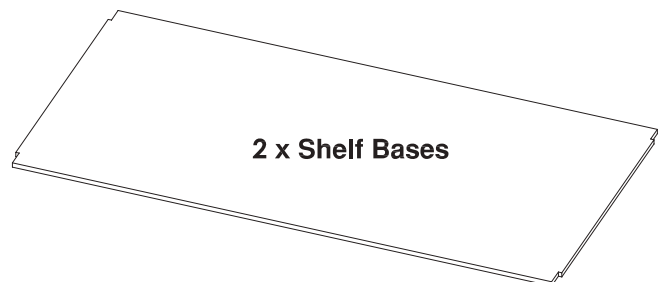

2 x Shelf Bases

ASSEMBLY INSTRUCTIONS

Step 1: Prepare the End Panels

End Panelの準備。

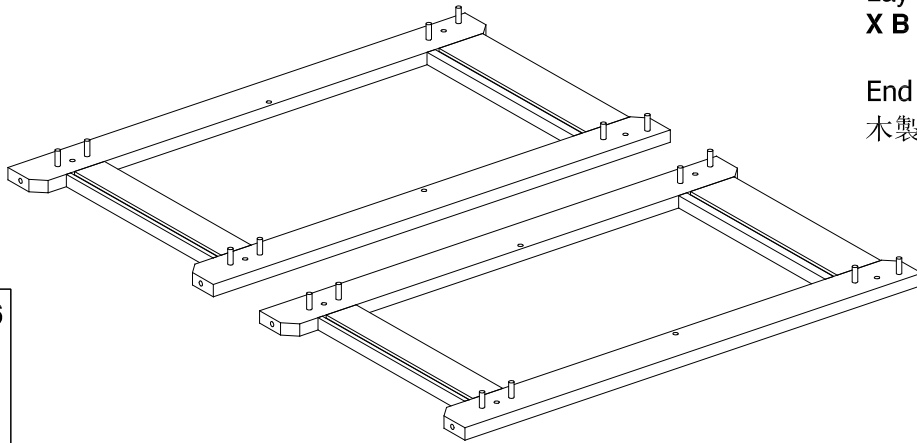

Lay **End Panels** flat onto floor and place **16 X B** wooden dowels into holes in sides.

End Panelの16か所の貫通していない穴に木製ネジを差し込みます。

B x 16



Step 2: Attach the Support Bars and Middle shelf to the End Panel

Note: Make sure the grooves on the Support Bars for the Shelf Base are facing inward.

End Panelに4本のCボルトでSupport Barを固定します。その際、溝が内側になるようにしてください。

また、下図のように2本のAボルトで中段の棚 (Middle Shelf) を固定してください。

Lay your **End panel** on its side and secure the **2 X Top Support Bars** and **2 X Lower Support Bars** using **4 X C** connecting bolts.

Secure the **Middle Shelf** with **2 X A** connecting bolts.

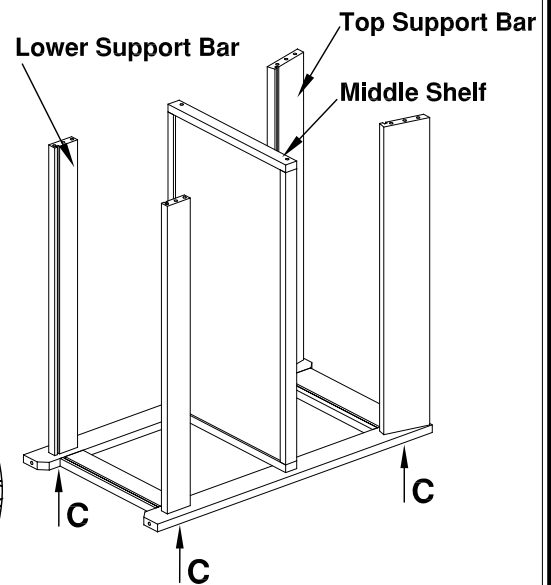

A x 2 C x 4

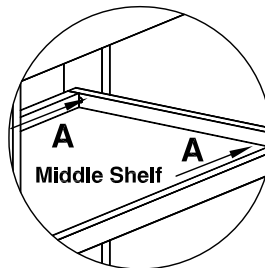
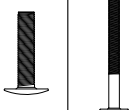

Step 3: Attach the Shelf Bases

Slide the two **Shelf Bases** into the grooves in the **Top Support Bars** and **Lower Support Bars**. Make sure the stained side is facing up.

上段と下段の溝に2枚のShelf Baseを差し込みます。

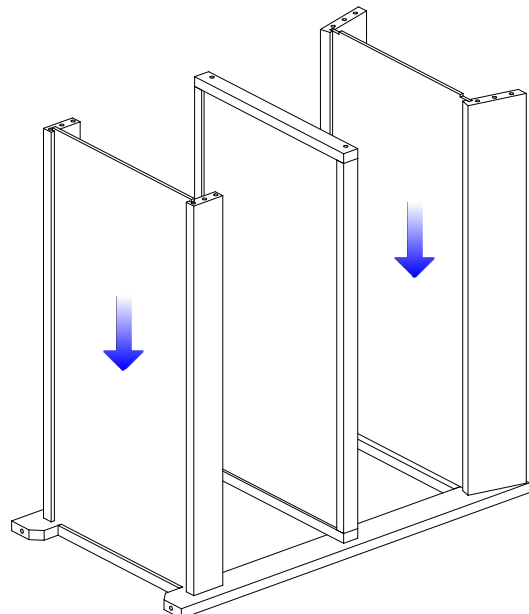

ASSEMBLY INSTRUCTIONS

Step 4: Attach another End Panel

Attach another **End Panel** onto the **Support Bars** and **Middle Shelf**, with **4 x C** connecting bolts and **2 x A** connecting bolts.

もう一方のEnd Panelを4本のCボルトでSupport Barに固定します。そして2本のAボルトでMiddle Shelfを固定します。木製ネジが落ちてしまう場合はサポートバー側に木製ネジを差してEnd Panelをのせてください。

A x 2 C x 4

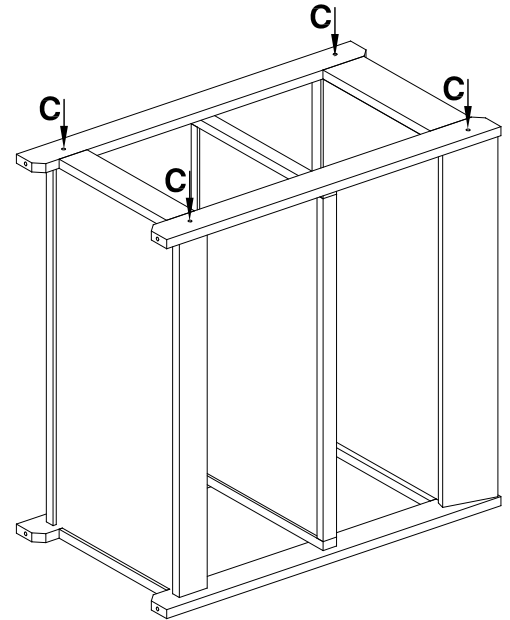
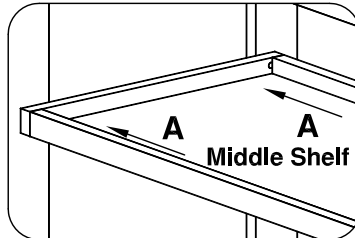
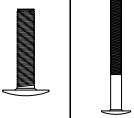

Step 5: Attach the Castors

Push the **4 x Castors** into the castor sleeves holes at the bottom of the **End Panels**.

End Panel底部の穴にキャスターを押し込んでください。
※キャスター以外に銀の筒のパーツが封入された製品があります。その場合は、筒をハンマーで底部にささるよう打ち込んでからキャスターを押し込んでください。

D x 4

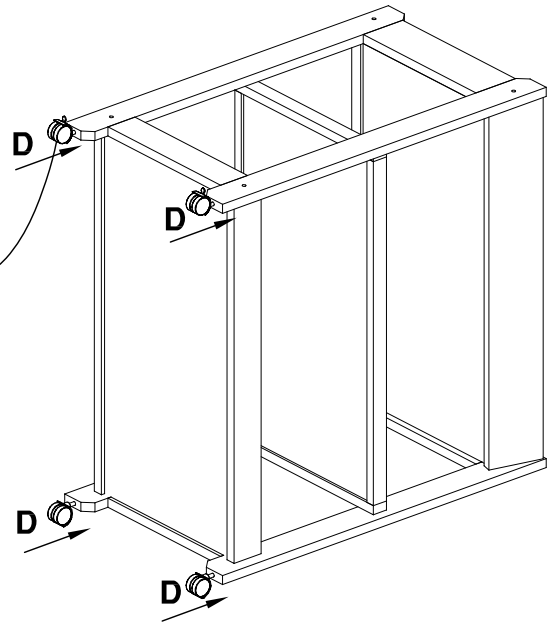
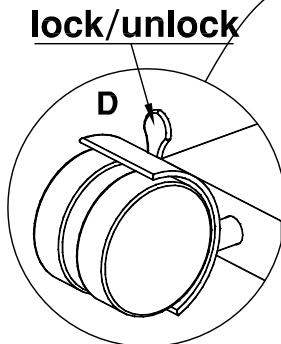

Note: After standing your **Changer** upright push down on the corners to make sure **Castors** click into place.

キャスターがしっかり入っていることを確認するために、直立させたあとで、上から押してください。

Put the changing pad onto the top of the **Changer**.

最上段にチェンジングパッドを敷いてご使用してください。

⚠ WARNING:

- * Please ensure that the brakes on all four castors are released before moving the cradle;
- * Regularly check your cradle to ensure that all the rocking bars are in their correct positions, and the capping nuts are tightly fitted.

移動させる際にはすべてのストッパーが解除されているかどうか確認してください。
定期的に全てのボルトがしっかりしまっていることを確認してください。

